



HALID YILDIRIM

COMPUTER ENGINEERING STUDENT

AHMET YESEVI UNIVERSITY



 halidyildirim64@gmail.com

 www.linkedin.com/in/halid-yildirim-849208203

 +90 531 823 67 80

 www.reddit.com/user/SMD_Human

 github.com/SMDHuman

 www.youtube.com/c/LimenitisReducta1

WORKING EXPERIENCE

- Microcontroller & Robotics Projects R&D Technician and Robotic/Python Instructor
Maker Eskisehir – Batıkent / Eskişehir, 02/01/2023 – Today
<https://www.makereskisehir.com/>
- Robotic and Python Instructor (Part Time)
Maker Eskisehir – Batıkent / Eskişehir, 18/08/2021 – 18/06/2022



EDUCATION & COURSES

- Computer Engineering - Ahmet Yesevi University (Kazakhstan) 06/2022 - Today
- Robotic Coding Instructor Certificate, 09/2019-10/2021
- Maker Eskisehir Coding With Python 2, 09/2019
- TUBITAK Science, Young Robot Science Event, 06/2015
 - *RS iDea Visual Programming*
 - *Algorithm Generation Software*
 - *Using Robot Components Training*
- Empathy Educational Institution,
Computer & Web Design Course, 01/2014 - 04/2014
 - *Simple & Advanced Web Operations with HTML*
 - *Style Template (CSS)*
 - *Web Design Introduction*
 - *Web Design Applications*
 - *Database Operations with Web Design*

HONORS & AWARDS

- **TUBITAK 52.**High School Students Research Projects **National** Competition
Awarded the Third Prize in Robotics & Coding 08/06/2021
https://tubitak.gov.tr/sites/default/files/2750/sonuclar_lise_web_liste_2021_0.pdf
- **INSPO 2021** International Science Projects Olympiad
Awarded the First Prize in Engineering 05/05/2021
<http://www.inspoturkey.com/organizasyon/inspo-2021/inspo-2021-final-sonuclari/>
- **TUBITAK 52.**High School Students Research Projects **Regional** Competition
Awarded the First Prize in Robotics & Coding 30/03/2021
https://www.tubitak.gov.tr/sites/default/files/2750/bursa_6.pdf
- Awarded as ElectroMaker of the Month November 2022 - 05/12/2022
With the project LOTP Robot Dog Prototype 2 by Electro{Maker} Community.
<https://www.electromaker.io/blog/article/electromaker-of-the-month-november-winners>
- Hackaday - 2022 FPV Contest awarded an honorable mention – 16/01/2023
With the project LOTP Robot Dog Prototype 2
<https://hackaday.com/2023/01/16/2022-fpv-contest-congratulations-to-the-winners/>



PRESENTATIONS & INVITED LECTURES

- Presentation at the Reddit Robotics Showcase on 31/07/2022.
Participated as a guest speaker to the event of r/Robotics Reddit community for introducing Modular Quadruped Robotic Vehicle (Robot Dog) LOTP V2.
<https://www.youtube.com/watch?v=TacX82KI1Sw&t=4322s>
- Project Promoted at Electro{maker} online maker community showcase on 18/01/2023.
Modular Quadruped Robotic Vehicle (Robot Dog) LOTP V2 has been awarded as ElectroMaker of the Month November 2022
<https://www.youtube.com/watch?v=akcZd1hx-9Y&t=231s>
- Guest speaker at City Talks organized by Tepebasi Municipality about The success story of TUBITAK 52.High School Students Research Projects National Competition Award on 06/09/2021
<https://www.youtube.com/watch?v=upFr-BmDTMM&t=1281s>
- Guest speaker at Mersin Youth Technology Summit for introducing Modular Quadruped Robotic Vehicle (Robot Dog) LOTP Version 2 on 19/05/2021
<https://genclikzirvesi.mersin.bel.tr>
- Interview on NTV "Stories of Hope" program about developing Robot Dog Project on 23/03/2021
<https://www.youtube.com/watch?v=7gtBkx693Ns&t=34s>

PARTICIPATION CERTIFICATES

- 2019 International Mathematics Kangaroo Competition Turkey, 23/03/2019
- TED Eskisehir College Social Activity Participation Certificate, 11/06/2019
- *Science Festivals* - *Model United Nations Club* - *Debate Club* - *Basketball*
- 7. Art Dance Course, 03/2019 - 06/2019
- TED Eskisehir College Career Development Summit "Hybrid Human", 14/12/2018
- Turkey United Nations Gender Equality & Women's Empowerment Group "From Beijing To Today, From Today To The Future", 08/03/2019
- TED Eskisehir College Debating Tournament Participation Certificate, 2018 - 2019 Education Period
- TED Eskisehir College Model United Nations Tedesmun, Tedesmun Conference as a Delegate in UNEP, 14/03/2019 – 17/03/2019
- Duet Art Piano Course 04/2013 - 06/2013

HOBİES & OTHER SKILLS

- Possession of valid driving license
- Languages: Turkish (native language), English (Upper-Intermediate Level - Duolingo Test Overall Score 90)
- Traveling foreign countries (Australia, Singapore, Indonesia, Kazakhstan, Pakistan, Tanzania)
- Boulderling, Swimming
- Polaroid photography
- Lego sets collection
- Retro technological device collection

MORE ABOUT ME

I was born in Ankara in 2003. Mechanic, Electronic and Software projects are my real passion. First I start preparing these projects by doing research and reading sources from internet and books. In this way, I learn academic disciplines, principles and fundamental knowledge which ensure me to realize projects. I see design and development phases as opportunities for implementing my point of view and original approach. I try to reflect my imagination and my own unique point of view to my projects as much as possible, and I try to add my own style. I see my mistakes in the development process as a step forward at this journey to get me to the right destination. The greatest success I have achieved in my projects is what I learned during the development process. I believe that every project I have accomplished, develops an infrastructure for upcoming projects to be more effective, stable and original, and that it prepares me for the future to be a good engineer.

My Dream is to be professional at Computer Science field. I would like to specialize on quantum computers or in artificial intelligence expertise fields. My biggest Aim is to be a competent scientist in these developing and promising branches of science and to contribute to all humanity.



RESEARCH & PROJECTS

• *BitBoard Bir (Real-Time Logic Simulator Dev-Board) (01.2023 – Today)*



- ESP32 based microcontroller
- with built-in 1.3 inch TFT display at 240 by 240 resolution 16 bit RGB colors
- has 24 GPIO which 12 of them can be used for ADC
- has a circuit simulator & generic logic simulator can be seen its own display
- it can simulate circuits up to 10 kHz
- programmable with Arduino and MicroPython languages
- supports I2C, SPI and UART protocols
- internal clock runs up to 240 MHz
- its wireless module supports Bluetooth and Wi-Fi
- 8 combinable expansion packs
 - . 9 axis IMU Pack for sensing movement and direction
 - . Environment Pack (light, humidity, temperature sensors and barometer)
 - . Controller Pack (2 joysticks, 2 switches, 4 direction buttons, and 2 controllable LEDs)
 - . Robot Pack (capacity to control up to 14 servos and 2 DC motors)
 - . Battery Pack with 1 Li-Po battery
 - . VGA Pack with a VGA port to display images on the monitor
 - . Keyboard Pack (60 keys with mini keyboard layout)
 - . Prototyping board (with bunch of holes for making expansion packs)



<https://www.youtube.com/watch?v=qDHrI9Wefic&list=PL7D6gXmaTbgJY7uyk1sXHLi52KbjsbVvM&index=1>

● **SCUTTLE Self-Balancing Robot (05.2023)**



This project is sponsored by Scuttle Robotics and Viam.

SCUTTLE™ Robot's Standard form is a stepper motor driven and Raspberry Pi Pico based Four-wheeled robot. This Open Source project has been converted to a 2-wheeled self-balancing robot. Hardware has been transformed from Standard Model to Self-Balanced adaptable Form

Custom 3D Printed Part has been designed in Fusion 360 to hold MPU6050 sensor on chassis.

Self-Balancing Software was written in Python and PID Controller implemented.

Software for reading and evaluating of MPU6050 sensor's Data was written in Python.

Project Documentation has been prepared and shared as Open Source DIY project.

<https://github.com/SMDHuman/ScuttleBalancingRobot>

<https://www.youtube.com/watch?v=9dzYoOkwppww&list=PL7D6gXmaTbgJOn8mXaZHYi5GAXgFns2S0&index=4>

● **8 Bit Computer Processor on Breadboard (04.2023 – Today)**

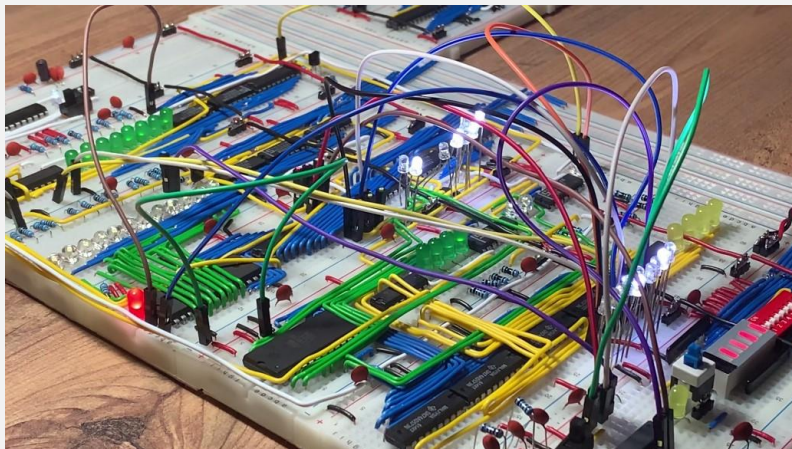

- 8 Bit Processor in CISC architecture, Built on Breadboard
- TTL Transistor Logic Chips used
- Running Assembly Language
- Adjustable Processor Clock Speed from 10 Hz to 10,000 Hz with TLC555 Chip
- Manual Mode Operation Option (for Debugging Purpose)
- Includes: Clock Module, Address Counter, Eprom Address Registers, Eprom and I/OUnits, Eprom Instruction Registers, Assembly Code EPPROM and counters, Micro Code EPPROMs (4 Registers), 32 Instruction Process Capacity, BUS Input Output Pins, Debugging Units (Data Reading Interface and Eprom Edit Buttons), A and B register (Memory Blocks) (2 x 8 Bit Data) for mathematical operation

<https://www.youtube.com/watch?v=9bV2f2t2o0I>

• **LOTP VLIC v1 (Virtual Logic Integrated Circuit) - (07.2022 - Today)**

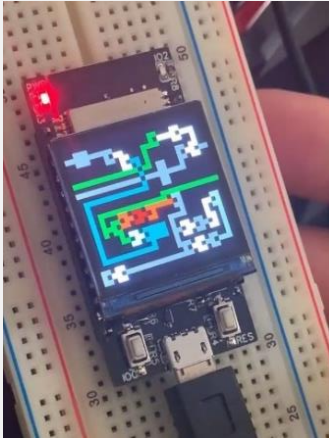

- . SP32 based design
- . EasyEDA design software
- . Logic simulator
- . Circuit visualizer
- . Microcontroller based logic emulator
- . DIY PCB build and design
- . Uploader and compiler code in python
- . Visualizer and emulator code on Arduino

https://www.youtube.com/watch?v=qjQl6Ofm_bA

• **LOTP Two-Wheeled Self-Balancing Robot - (09.2022)**

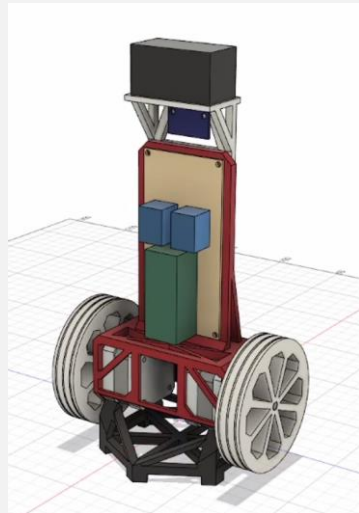
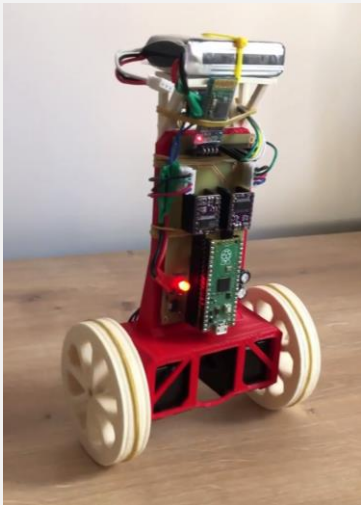

- . Fusion 360 designed
- . Bluetooth control is available
- . Software is written in Python
- . PID Controller implemented
- . Open Source
- . <https://github.com/SMDHuman/BalanceWheel>
- Printed with Ender 3 Max (3D Printer)
- . Raspberry Pi Pico used as a micro controller
- . Stepper Motors are used to perform movement
- . Self - Balancing
- . DIY Project

Article written by independent blogger

<https://hackaday.com/2022/12/27/3d-printed-self-balancing-robot-brings-control-theory-to-life/>

More about Project:

<https://www.youtube.com/watch?v=LykbhLb3tnc>



• **LOTP Robot Dog Ver.2 Modular Quadruped Robotic Vehicle - (09.2020 - 01.2021)**

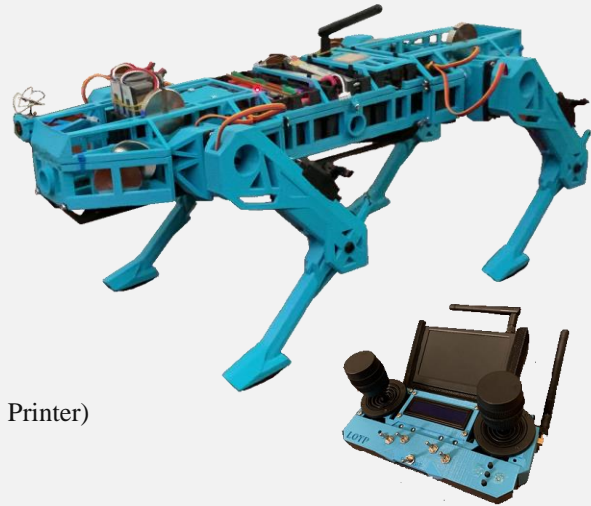
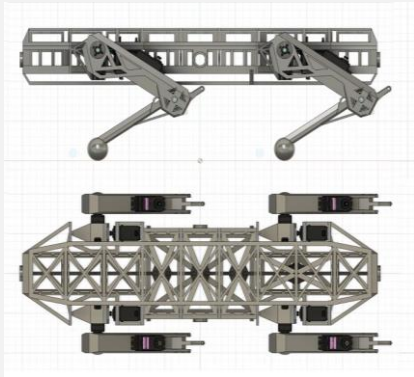

- Designed with Fusion 360 and printed with Anet A8 (3D Printer)
- Coded in Arduino language on Teensy 3.5 & Arduino
- Circuit Diagrams designed on Fritzing
- Modular structure (Lidar, Drone, Gas detection)
- Sensors Capacity: Lidar, Gas detection, Pressure sensors, Gyroscope, GPS, Wi-Fi connection
- Autonomous features (Avoiding obstacle, maintain balance, pressure control)
- PI (Proportion - Integral) control
- Inverse Kinematics & Kinematics formulas applied
- Remote Controller access through WiFi
- FPV Camera and Monitor setup
- Open Source <https://github.com/SMDHuman/LOTPRobotdog2>
- More about Project: <https://www.youtube.com/watch?v=BUy5MB7Do1M>

Articles written by independent bloggers

- <https://www.electromaker.io/blog/article/electromaker-of-the-month-november-winners>
- <https://www.hackster.io/news/lotp-robot-dog-is-a-modular-quadruped-robotic-vehicle-that-can-be-enhanced-over-time-f47825c0e372>
- <https://hackaday.com/2022/12/21/2022-fpv-contest-the-lotp-robot-dog/>
- Promoted by Electro{maker}
- <https://www.youtube.com/watch?v=akcZd1hx-9Y&t=231s>



• **LOTP Robot Dog Ver.1 - (04.2020 – 08.2020)**

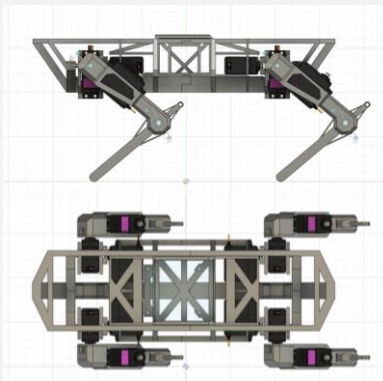

- Designed with Fusion 360
- Designed as a compact structure.
- Remote Controller access through WiFi
- Software written in python language
- Open Source <https://github.com/SMDHuman/LOTP-RoboDog>
- More about Project: <https://www.youtube.com/playlist?list=PL7D6gXmaTbgJysaQA2-NCmtb6zKCfUJtX>
- Printed with Anet A8 (3D Printer)
- Raspberry pi 3A+ used
- Circuit Diagrams designed on Fritzing
- Kinematics formulas applied

• **LOTP Mini PCB CNC - (01.2019 – 03.2019)**

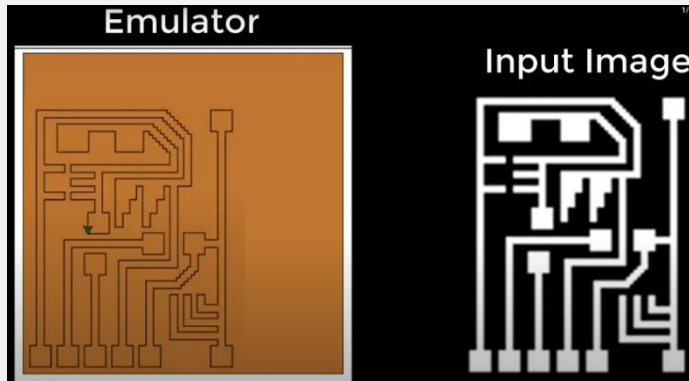

- Designed with Fusion 360
- Printed with Anet A8 (3D Printer)
- Unique CNC control & CNC route planning algorithms
- Coded in Python
- Raspberry pi zero used
- Project is for producing prototype circuit boards

More about Project:

<https://www.youtube.com/watch?v=jYmVvCx-emk>

• **LOTP CPU - (01.2018 – 03.2020)**

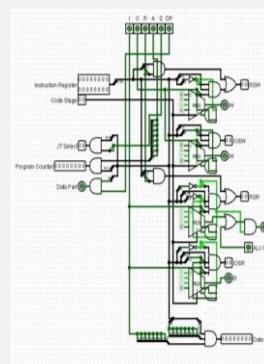
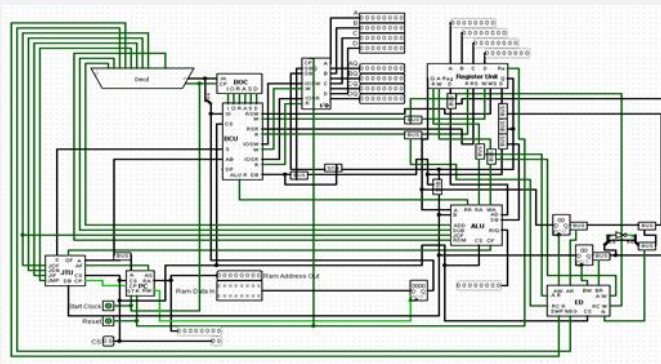

General features of my microprocessor can be listed as follows. It is an 8 bit processor and a total of 12 different Assembly commands are running on it. These are transferring data from a register to a register, collecting and extracting data from a register, unconditional jump of the code into one line, jump to a certain line of the code according to a condition (comparison of two digits, over flow on ALU), jump to the desired line of the code with the data in the register, replace the data in two registers, changing the load (+ -) of data in a register, reading or writing data from any address of the cache, and generating random numbers. In addition, 4 of the 8 registers can be used as input and output outside the processor. It has been designed and tested on LogiSim.

More about Project:

<https://www.youtube.com/watch?v=D-gDCu7c9OA>

● *Exoskeleton - (07.2018)*



I made this design by only using cardboard, toothpicks, rubber and hot glue. This project expresses to me that we can continue to imagine and produce even when the possibilities and resources are limited.

While designing, I examined the human bone and joint structure and paid attention to its ergonomics.

I chose to make it out of cardboard because I wanted to be able to make changes on the entire outer frame easily. I prepared the design drawings for the next version of this project figure. Designing it with 3D Model printing is another project that I am planning to work on it in the future.

More about Project:

<https://www.youtube.com/watch?v=RSyLSsmXWNk>

● *Robotic Arm - (12.2015)*

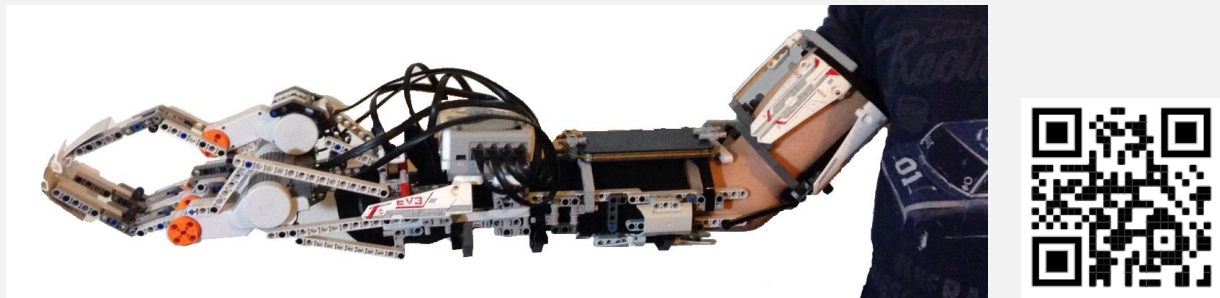

It is a project that I participated in the Turkish World Olympics. In the competition, it was shortlisted as one of the projects representing my school and the city of Eskisehir. I developed it using Lego Mindstorm sets. The aim of the project is to make a mechanical hand that can be used to remove earthquake victims under the debris and stuck in the vehicle at the accident site, repeating the movements of our hand simultaneously at the same time with an increased force. I prepared the prototype of this design that could be produced as a hydraulic arm in the future. Touch buttons on the fingertips control the servo motors corresponding to the fingers on the mechanical hand. I programmed control algorithms on the main computer of the Lego Mindstorm set.

More about Project: <https://www.youtube.com/watch?v=L1eig1LaYmk>

● *Python Projects - (2017 - Today)*

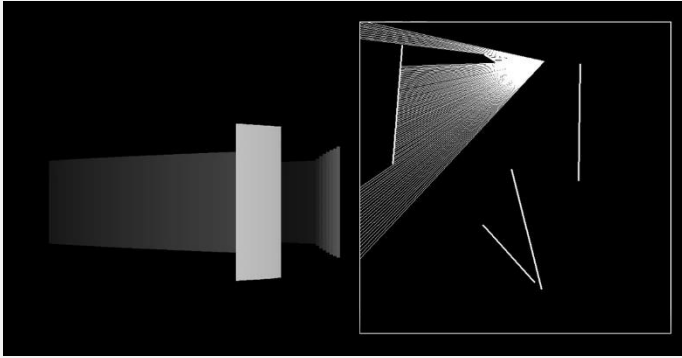

2DRay Casting



Custom Colour Palette Creator

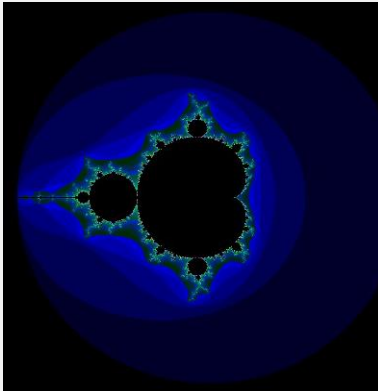

Mandelbrot Set Renderer

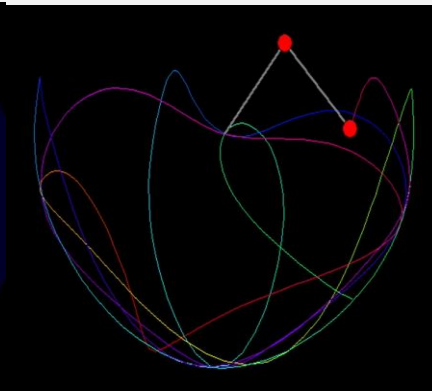

Double Pendulum

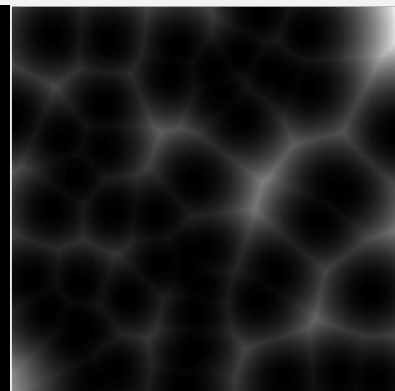

Worley Noise

Although python is not the first language I learned, it is the most stable and mastered programming language for me. When I started learning python, every project I worked on allowed me to learn python's new features and expand the limits of what I could do. I want to learn more and develop artificial intelligence applications in future.

These are some of the applications I developed on python:

- .Math Function Graphic
- .LOTP Lantern (3D Render Engine)
- .VScreen (Ascii Console Graphic Window)
- .Mandelbrot Set Renderer
- .Custom Color Palet Creator
- .Physic Engine
- .LOTP CPU Assembly Emulator
- .Double Pendulum
- .2D Ray Casting
- .Perlin Noise Loop
- .Marching Squares
- .Perlin Noise Particle Flows.
- .Worley Noise
- .Times Tables Cardioid Visualization
- .Tree Fractal
- .Collatz Conjecture Tree
- .Random Snowflake Generator

More about Project: <https://www.youtube.com/watch?v=SxhuLySY6xE>
https://www.youtube.com/watch?v=chE3Uf_F8k